



**SEALED LEAD ACID BATTERY  
PART No. BA27-01  
(BOEING P/N S281W501-2)**

**COMPONENT MAINTENANCE MANUAL  
WITH  
ILLUSTRATED PARTS LIST**

**DOCUMENT No.  
9602-0516 Rev. 04**





COMPONENT MAINTENANCE MANUAL  
BA27

RECORD OF REVISIONS

<i>REV No.</i>	<i>ISSUE DATE</i>	<i>INSERT DATE</i>	<i>BY</i>	<i>REV No.</i>	<i>ISSUE DATE</i>	<i>INSERT DATE</i>	<i>BY</i>
01	Apr 25/95						
02	Jun 30/95						
03	Apr 16/99						
04	June 09/06						









COMPONENT MAINTENANCE MANUAL  
BA27

SERVICE BULLETIN LIST

SERVICE  
BULLETIN  
NUMBER

REVISION  
NUMBER

DATE BULLETIN  
INCORPORATED  
INTO MANUAL

PRODUCT IMPROVEMENTS

Product improvements have been incorporated using service bulletins entered in the service bulletin list. Service bulletin highlights are as follows:





**COMPONENT MAINTENANCE MANUAL  
BA27**

LIST OF EFFECTIVE PAGES

<u>SUBJECT</u>	<u>PAGE</u>	<u>DATE</u>	<u>SUBJECT</u>	<u>PAGE</u>	<u>DATE</u>
Title	T-1	June 09/06	Disassembly	19	June 09/06
				20	June 09/06
Record of Revisions	R/R-1	June 09/06			
Record of Temporary Revisions	TR-1	June 09/06	Cleaning	21	June 09/06
				22	Blank
Service Bulletin List	SBL-1	June 09/06	Check	23	June 09/06
				24	Blank
List of Effective Pages	LEP-1	June 09/06	Repair	25	June 09/06
				26	Blank
Table of Contents	T/C-1	June 09/06	Assembly	27	June 09/06
				28	June 09/06
Introduction	INTRO-1	June 09/06		29	June 09/06
				30	Blank
Description and Operation	1	June 09/06	Special Tools,	31	June 09/06
	2	June 09/06	Fixtures &	32	Blank
	3	June 09/06	Equipment		
	4	June 09/06			
	5	June 09/06			
	6	June 09/06			
Testing and Fault Isolation	7	June 09/06	Illustrated Parts	33	June 09/06
	8	June 09/06	List	34	June 09/06
	9	June 09/06		35	June 09/06
	10	June 09/06		36	June 09/06
	11	June 09/06			
	12	June 09/06			
	13	June 09/06			
	14	June 09/06			
	15	June 09/06			
	16	June 09/06			
	17	June 09/06			
	18	Blank			





COMPONENT MAINTENANCE MANUAL  
BA27

TABLE OF CONTENTS

<u>Paragraph Title</u>	<u>Page</u>
Description and Operation .....	1
Testing and Fault Isolation .....	7
Automatic Test Requirements (not applicable) .....	
Disassembly .....	19
Cleaning .....	21
Check .....	23
Repair .....	25
Assembly .....	27
Fits and clearances (not applicable) .....	
Special Tools, Fixtures and Equipment .....	31
Illustrated Parts List .....	33





## COMPONENT MAINTENANCE MANUAL BA27

### INTRODUCTION

The instructions in this manual provide the information necessary for an experienced shop mechanic to service and if required, re-block batteries with no specialised training.

The manual is divided into separate sections:

- |                            |                                |
|----------------------------|--------------------------------|
| 1. Title page              | 4. Table of Contents           |
| 2. Record of revision      | 5. Introduction                |
| 3. List of Effective Pages | 6. Procedures and IPL Sections |

The disassembly, repair and assembly sections generally contain only specific instructions to be used on the equipment covered herein. Most standard aerospace practices are not described herein.

An explanation of the use of the illustrated Parts List (IPL) is provided in the introduction to that section.

All weights and measurements in the manual are in English units, unless otherwise stated.

The BA27 battery is manufactured by:

**EnerSys Ltd**  
Stephenson Street  
NEWPORT  
S. Wales  
NP19 4XJ  
U.K.

Tel: +44 (0) 1633 277673

Fax: +44 (0) 1633 281787

#### *Verification:*

Testing/Fault Isolation	June 09/06
Repair	June 09/06
Disassembly	June 09/06
Cleaning	June 09/06
Assembly	June 09/06





## COMPONENT MAINTENANCE MANUAL BA27

### DESCRIPTION & OPERATION

#### 1. Description

The EnerSys 24 volt 5 ampere-hour Sealed Lead Acid Battery, covered by this Maintenance Manual (Ref. Fig. 1) is connected to the Flight Controls DC Power Supply Assembly to produce fill-in power to its Flight Controls DC Bus while switching between permanent magnet generator (PMG), transformer rectifier unit (TRU) and Hot Battery Bus Sources.

The Battery consists of two 12-volt Sealed Lead Acid monoblocs connected in series, enclosed in a metal outer case, which incorporates the battery main terminal connector.

Each Monobloc incorporates resealing safety valves to guard against the effects of abusive use of the battery.

As the EnerSys Flight Controls (FC) battery is sealed, there are no restrictions as to transportation. The batteries are classified as non-hazardous cargo when transported by air, land or sea.



COMPONENT MAINTENANCE MANUAL  
BA27

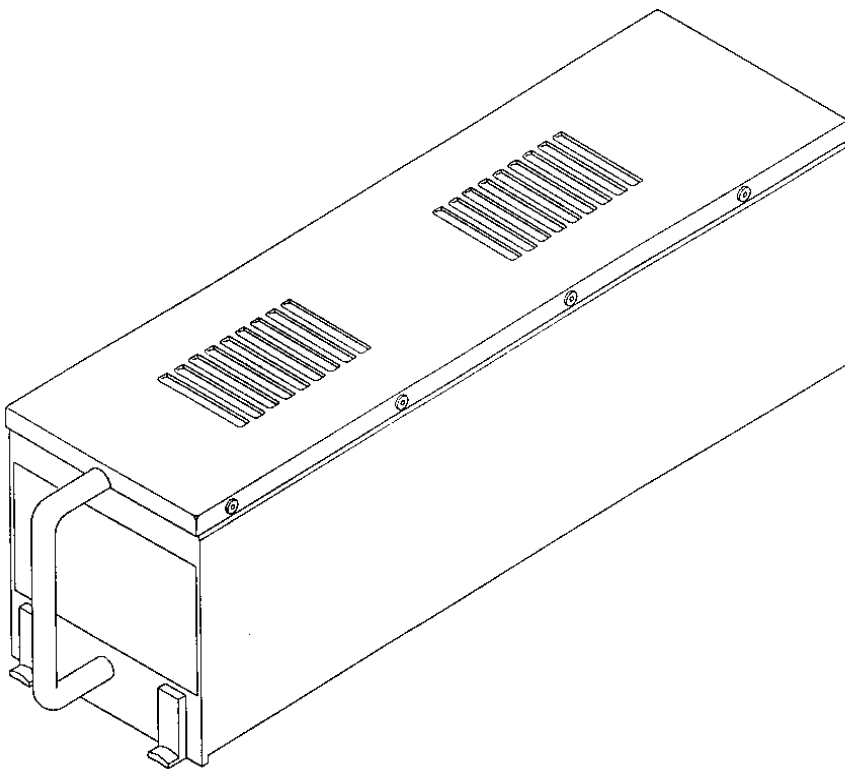

Sealed Lead Acid Battery

Figure 1



## COMPONENT MAINTENANCE MANUAL BA27

### 2. Operation

#### A General

The battery is charged (and also sustained) on the aircraft by a modified constant potential mode via a series 0.75 ohm resistance and relay contacts from the flight controls dc bus within the Flights Controls Power Supply Assembly. Whenever the aircraft engines are in operation, the relay contacts are closed and the flight controls dc bus is powered from two regulated converters supplying a regulated 28.2 V dc. When the aircraft engines are not in operation (ground operation), the battery is connected to the flight controls bus via the 0.75 ohm resistance and relay contacts only when the voltage on the flight controls bus is within the range of 26.5 V dc and 30.0 V dc. Under operation with ground service power, the flight controls dc bus voltage is normally between 27.0 and 27.5 V dc. The operation of the relay contacts that connect the battery (via the resistance) to the flight controls dc bus is controlled by logic circuitry within the Flight Controls Power Supply Assembly.

The battery is capable of supporting short duration fill-in and path check loads of approximately 15 A dc as well as a parasitic demand of 1.5 mA dc (when the airplane is without electrical power) and an emergency condition loading of up to 30 A dc for up to one minute duration. The worse case daily usage (with twelve flights per day) and with no emergency is approximately 0.25 Ah.

**CAUTION:** The battery is maintenance free. Under no circumstances should any attempt be made to introduce any substances, e.g., acid, distilled water or alkali, to the battery.

#### B Temperature Effect

The ideal environmental temperature for battery operation is 23°C (73°F) to 25°C (77°F). Long-term exposure to temperatures above 30°C (86°F) can shorten the life of the battery.

As the temperature falls, the available capacity of the battery is reduced, which causes a reduction in performance. However, this is not a permanent condition and the capacity will be restored as the temperature rises. Long-term exposure to low temperatures will not damage the battery.



## COMPONENT MAINTENANCE MANUAL BA27

### C State of Charge

The battery is designed to commence discharge when the open circuit voltage (OCV) is within the 80 - 100% of nominal capacity range. At no time should the battery OCV be below 25.4 volts.



## COMPONENT MAINTENANCE MANUAL BA27

The graph in figure 2 demonstrates the effect of temperature on battery capacity at various discharge rates.

DISCHARGE PERFORMANCE (SELECTED DISCHARGE RATINGS)  
AS A FUNCTION OF TEMPERATURE

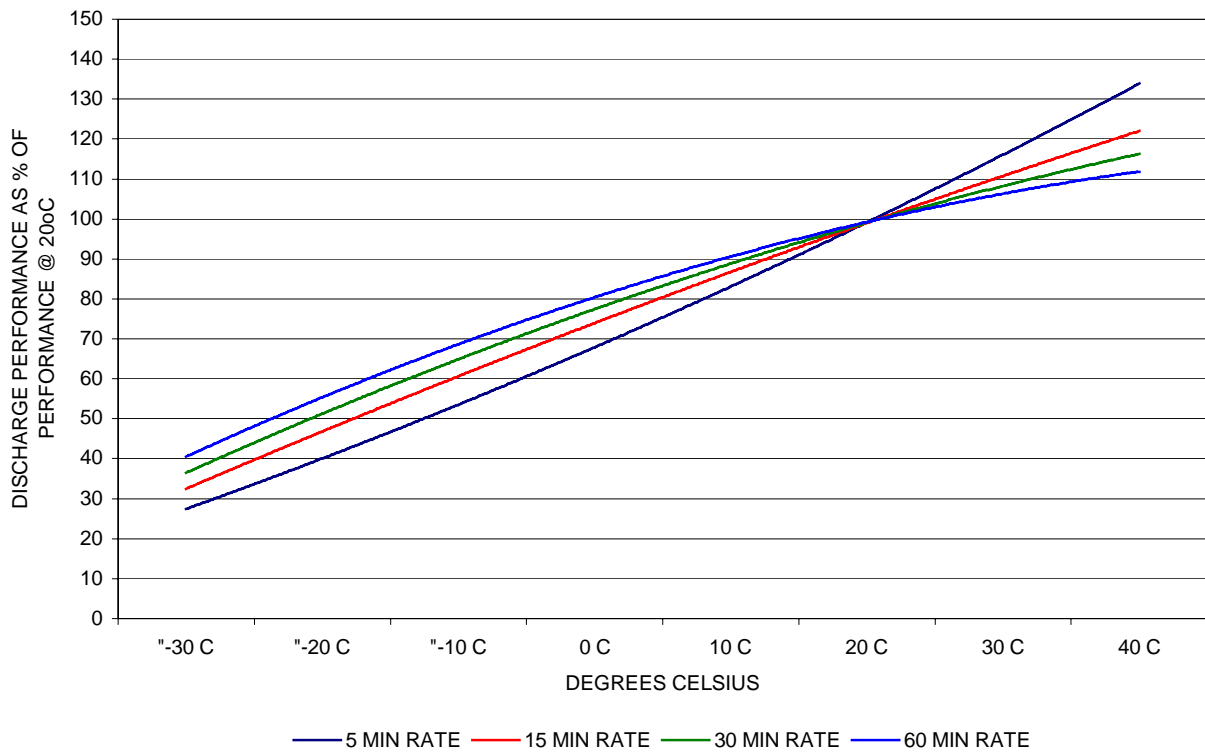

Variation in Performance with Discharge Temperature

Figure 2



## COMPONENT MAINTENANCE MANUAL BA27

### General Information

Battery Voltage: Nominal 24.0 Volts  
Battery Weight: 6.577 Kg Max. (14.5 lbs)

Dimensions:	Overall Height	115.00 mm Max.	(4.528")
	Overall Width	92.00 mm Max.	(3.622")
	Overall Length	324.00 mm Max.	(12.756")
	Handle Extension	35.60 mm Max.	(1.402")

Connector: ITT Cannon DPXBMA-10-34S-0015

Rated Capacity: 5 ampere-hours at the one hour rate

Monobloc Case Material: ABS Cycolac Grade G151

Battery Case Material: 1.2 mm thick NS4 (Al/Mg<sup>2</sup>)

### Leading Particulars

Figure 3



COMPONENT MAINTENANCE MANUAL  
BA27

TESTING AND FAULT ISOLATION

1. General

This section contains battery functional tests and fault isolation information. Trouble shooting is presented in chart form (Ref. Fig.8).

2. Required Test Equipment (Ref. Fig. 4).

NOTE: Test equipment having equivalent specifications can be used.

<i>NOMENCLATURE</i>	<i>MFR</i>	<i>MODEL/PN</i>	<i>APPLICATION</i>
DC Power Supply, regulated, 40V dc @ 10A minimum. (this can be replaced by the following Charger/Analyser)	Mead		Testing/F1
	Mead	Charger/ Analyser	Testing/F1
DC Voltmeter, precision ( $\pm 0.5\%$ ) 0 to 50V	Fluke	Fluke 85	Testing/F1
Discharge unit Capable of 5,10 & 30 Amp discharge.	Digatron	RCT 50-24	Testing/F1

Required Test Equipment

Figure 4



## COMPONENT MAINTENANCE MANUAL BA27

### 3. Test Equipment Set Up

#### A. Capacity Testing

Connect the battery to the discharge test unit in accordance with figure 5.

#### B. Recharging

Connect the battery to the charging unit in accordance with figure 5.

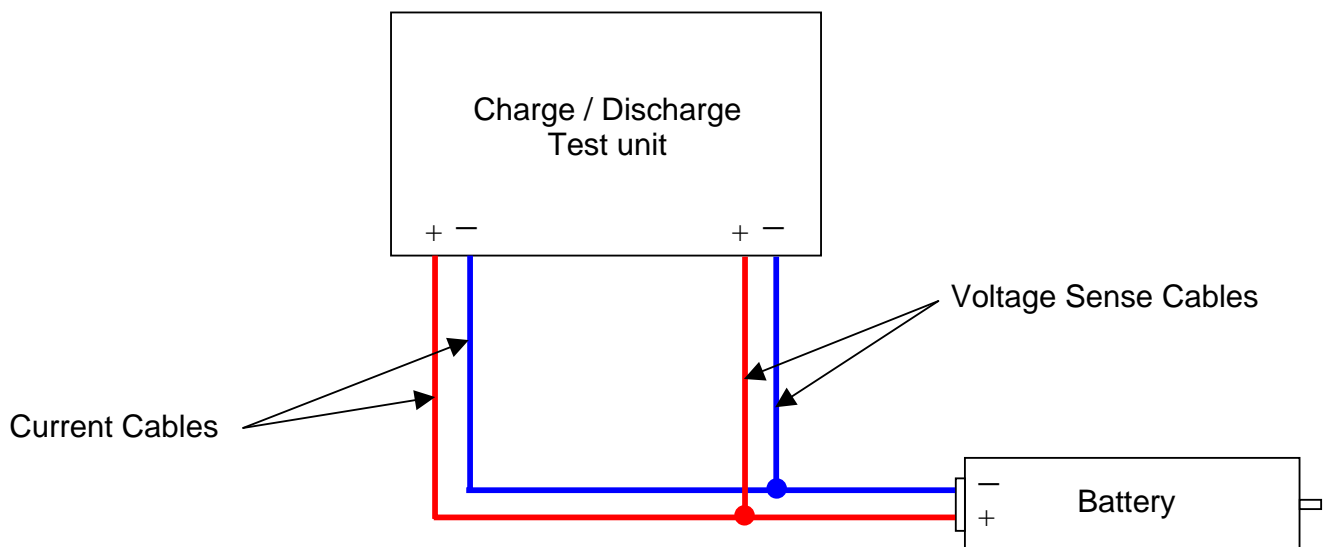

Figure 5



## COMPONENT MAINTENANCE MANUAL BA27

### 4. Testing

#### A. Test Equipment

Refer to Figure 4 for test equipment recommendations.

#### B. Condition of Batteries on Receipt

All batteries are despatched from manufacturer in a fully charged condition, the date of the latest charge being marked on the outer packaging.

#### C. Unpacking and Acceptance Checks

**NOTE:** The only acceptance check required immediately upon receipt is to look for signs of damage in transit. Unpacking and detailed examination is unnecessary and should be left until the battery is removed from storage.

#### D. Storage

It is recommended that the fully charged battery be stored in a cool dry place, at or below 25°C (77°F). Under these conditions the battery can be stored for 2 years. When subjected to storage or long-term exposure in excess of this temperature, battery charge retention will be reduced and possible performance degradation could occur.

It is mandatory to conduct an inspection and open circuit voltage check after 2 years and boost charge in accordance with paragraph G. if necessary, when stored at or below 25°C (77°F). If stored above 25°C and below 35°C, conduct an inspection and open circuit voltage check after 12 months. If stored above 35°C, conduct an inspection and open circuit voltage check after 6 months.



## COMPONENT MAINTENANCE MANUAL BA27

The battery may be stored up to 5 years at or below 25°C without degradation of performance provided that an inspection and open circuit voltage check is conducted every 12 months following the initial 2-year storage period. When stored at temperatures above 25°C and below 35°C the battery should be inspected every 12 months following the initial 12 months storage period. When stored at temperatures at or above 35°C the battery should be inspected every 6 months.

**NOTE:** A BOOST CHARGE IS TO BE CARRIED OUT AT EACH PERIODIC INSPECTION IN ACCORDANCE WITH PARAGRAPH G. IF NECESSARY.

The graph in Figure 6 demonstrates typical capacity retention of the battery during storage without regular boost charges.

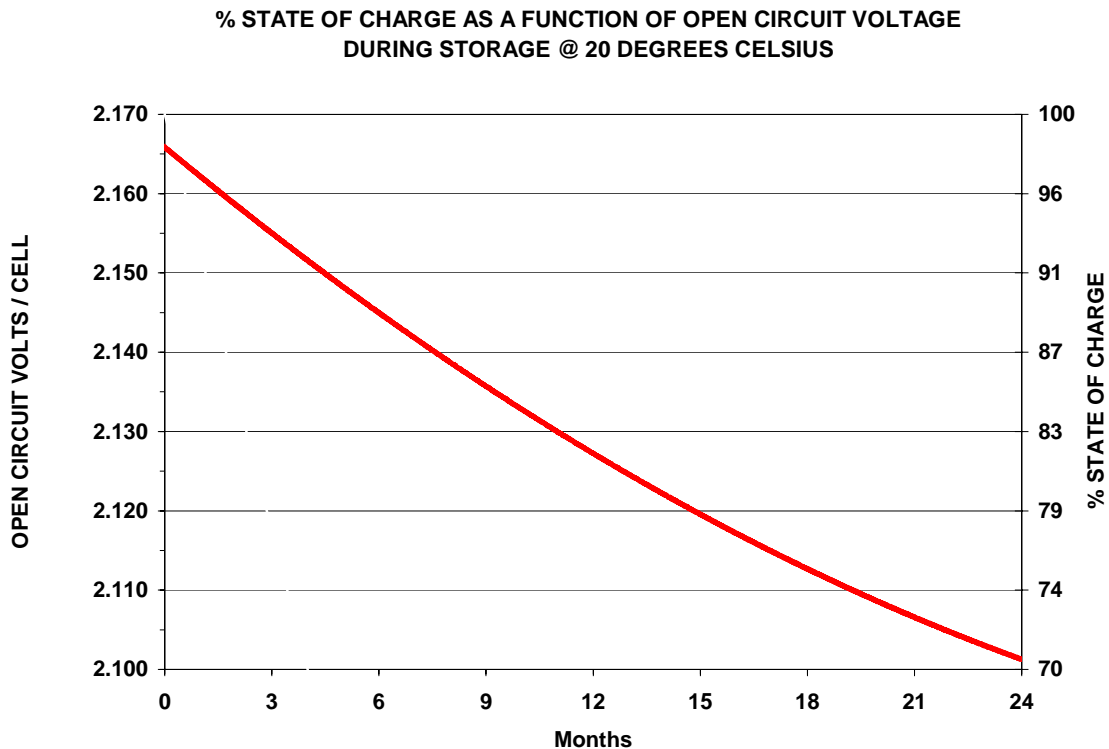

Charge Retention During Storage

Figure 6



## COMPONENT MAINTENANCE MANUAL BA27

### E. State of Charge

The open circuit voltage of the battery can be used as a guide to the state of charge of the battery. The graph in Figure 7 is an indicator as to the state of the charge of a new battery.

STATE OF CHARGE AS A FUNCTION OF OPEN CIRCUIT VOLTAGE

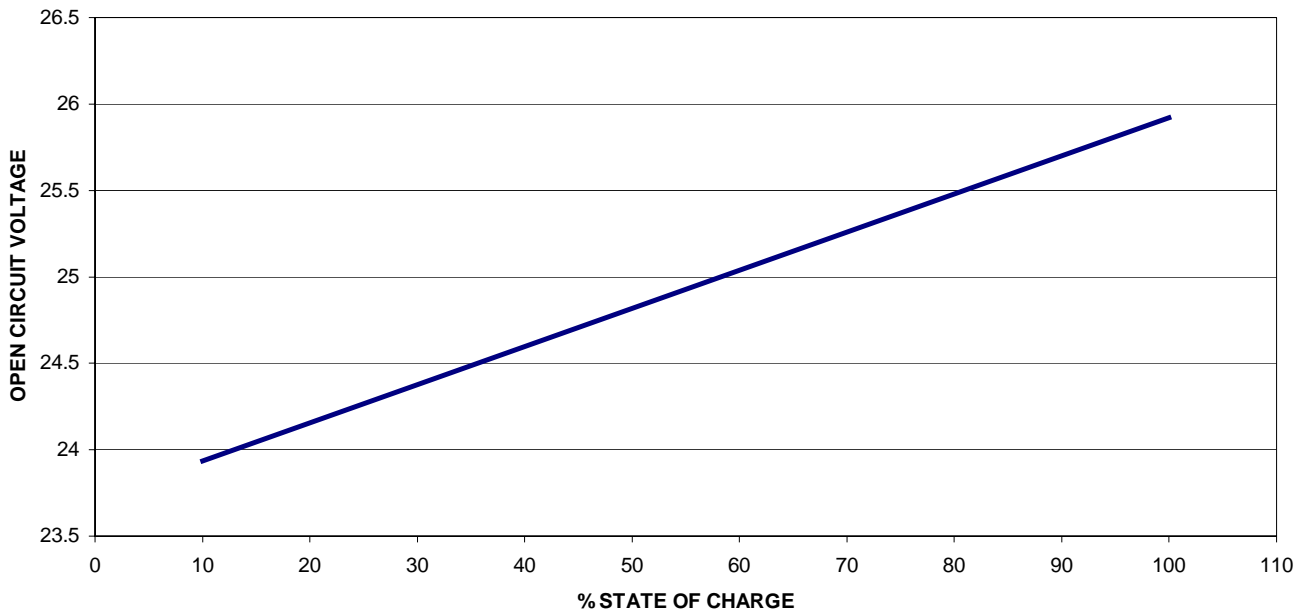

Open Circuit Voltage v SOC

Figure 7



## COMPONENT MAINTENANCE MANUAL BA27

**NOTE :** A dedicated lead acid battery charging room is not required for battery commissioning. A normal electrical workshop may be used and the battery can even be commissioned in a Nickel Cadmium battery room without fear of contamination.

### F. Commissioning Procedure

- (1) Visually inspect the exterior of the battery casing for signs of damage, cracks, corrosion, etc.
- (2) Examine the battery terminal connector for signs of corrosion, damage and water/dirt ingress; clean if necessary.
- (3) Check open circuit voltage, if the open circuit voltage is greater than or equal to 25.7 volts, the battery can be fitted to the aircraft.
- (4) If the open circuit voltage is greater than or equal to 25.3 volts but lower than 25.7volts, charge in accordance with paragraph G.
- (5) If the open circuit voltage is below 25.3 volts: -
  - (a) Charge the battery in accordance with paragraph G.
  - (b) On completion of recharge, allow the battery to stand open circuit for minimum of 4 hours for the battery voltage to stabilise.
  - (c) Carry out a capacity test. Discharge the battery at 5 amps to an end voltage of 20.0 volts.



## COMPONENT MAINTENANCE MANUAL BA27

- (6) If the discharge duration is greater than 60 minutes, recharge the battery in accordance with paragraph G, ensure the battery is clean and issue for use.
- (7) If the discharge duration is less than 60 minutes, recharge the battery as detailed in paragraph G.
- (8) On completion of the charge, allow the battery to stand open circuit for a minimum of 4 hours for the battery volts to stabilise.
- (9) Conduct a further discharge test as described in paragraph F (5)(c).
- (10) If the discharge duration is now in excess of 60 minutes, recharge the battery in accordance with paragraph G. Ensure the battery is clean and issue for use.
- (11) If the discharge duration is still below 60 minutes, reject the battery in accordance with paragraph I of this maintenance manual.

### G. Charging Instructions

Charging of the Flight Controls battery should be performed using a constant voltage charger, capable of constantly supplying 28.5 volts with a minimum supply current of 10 amps. Using the set-up illustrated in figure 5. (Minimum charge time 6 hours)

**NOTE:** Charging should be conducted between 20°C (68°F) and 30°C (86°F). The battery capacity may vary if charged outside this recommended temperature range.



## COMPONENT MAINTENANCE MANUAL BA27

### H. Battery shop test upon removal from aircraft

- (1) In normal service this battery should not need to be removed from the aircraft for the duration specified in the Boeing Commercial Airplane Company Maintenance Planning Document.
- (2) If however, as a result of a battery fault indication on the aircraft, the battery is removed for investigation, follow the fault finding procedure below.
- (3) Fault Finding Procedure:

There are two options available for carrying out the fault finding procedure depending on the available discharge equipment.

#### a.) Option 1 – Using a 10 Amp discharge unit:

- i.) Check the battery open circuit voltage.
- ii.) Recharge the battery in accordance with paragraph G.
- iii.) Allow the battery to stand open circuit voltage for 4 hours minimum.
- iv.) Discharge the battery at 10 Amps to an end voltage of 21.0 volts or 8 minutes whichever is achieved first.
- v.) If a discharge duration of 8 minutes is achieved, recharge the battery in accordance with paragraph G and return to service.
- vi.) If the discharge duration is less than 8 minutes, recharge the battery in accordance with paragraph G. Allow the battery to stand open circuit for a minimum of 4 hours before repeating steps (iv) and (v).
- vii.) If the second discharge duration is still less than 8 minutes, recharge the battery in accordance with paragraph G and follow the rejection procedure.



## COMPONENT MAINTENANCE MANUAL BA27

### b.) Option 2 – Using a 30 Amp discharge unit

- i.) Check the battery open circuit voltage.
- ii.) Recharge the battery in accordance with paragraph G.
- iii.) Allow the battery to stand open circuit voltage for 4 hours minimum.
- iv.) Discharge the battery at 30 Amps to an end voltage of 21.0 volts or 2 minutes whichever is achieved first.
- v.) If a discharge duration of 2 minutes is achieved, recharge the battery in accordance with paragraph G and return to service.
- vi.) If the discharge duration is less than 2 minutes, recharge the battery in accordance with paragraph G. Allow the battery to stand open circuit for a minimum of 4 hours before repeating steps (iv) and (v).
- vii.) If the second discharge duration is still less than 2 minutes, recharge the battery in accordance with paragraph G and follow the rejection procedure.



## COMPONENT MAINTENANCE MANUAL BA27

### I. Rejection Procedure

If the battery fails any of the procedures listed below: -

- Commissioning
- Battery shop test upon removal from aircraft

it should be rejected and notification of failure sent to the manufacturer.

#### **EnerSys Ltd**

Stephenson Street  
NEWPORT  
South Wales  
NP19 4XJ  
UK

Telephone: +44 (0) 1633 277673

Fax: +44 (0) 1633 281787



COMPONENT MAINTENANCE MANUAL  
BA27

5. Fault Isolation

Trouble shooting information is presented in Figure 8 as a guide in locating a cause of malfunction and isolating the cause to a specific component.

<i>TROUBLE</i>	<i>PROBABLE CAUSE</i>	<i>REMEDY</i>
Zero battery voltage	Broken or loose terminal connections.	Repair per repair instructions.
Loss of battery capacity	In service charging malfunction.	Run electrical test. Check aircraft charger.
	Defective cell	Run electrical test
Low voltage output	In service charger malfunction, loose terminal connection.	Run electrical test. Check aircraft charger.

Fault Isolation

Figure 8





## COMPONENT MAINTENANCE MANUAL BA27

### DISASSEMBLY

#### 1. General

This section describes and provides the information necessary for an experienced shop mechanic to re-block batteries with no specialised training.

#### 2. Safety

WARNING: Caution shall be exercised when testing, building and handling batteries, as monoblocs are fully charged and any short circuit condition may result in injury.

WARNING: To avoid risk of injury, care shall be taken when wearing jewellery such as rings, bracelets, metal watchstraps, necklaces and belt buckles.

CAUTION: Any such items shall if possible, be removed prior to working on monoblocs or batteries to avoid risk of injury.

CAUTION: All tools coming into contact with the monobloc terminals shall be fully insulated to prevent the risk of a short circuit condition.



## COMPONENT MAINTENANCE MANUAL BA27

### 3. Detailed Instructions

**NOTE:** The ( ) part identification numbers herein are detailed in IPL, Fig.1 item numbers.

- A. Remove cover (180) by carefully drilling out the 10 rivet fastenings (210).
- B. Remove the four monobloc terminal nut covers (150).
- C. Remove the binx nut (140), plain washer (130), and wire from the positive terminal of the rear monobloc (Ref Fig. 1). The nut and washer should be discarded.
- D. Remove the binx nut (140), plain washer (130), and wire from the negative terminal of the front monobloc (Ref Fig.1). The nut and washer should be discarded.
- E. Remove the binx nuts (140), plain washers (130) and series lamination (120) connecting the two monoblocs. The nuts, washers and laminations should be discarded.
- F. Cut wire ties (100) from the positive and negative wires.
- G. Remove the anti-vibration block (160).
- H. Remove the two monoblocs (20) from the outer battery case (30).
  - (1) Gently prise apart the case walls in the centre and remove the monobloc adjacent to connector block.
  - (2) Slide the second monobloc to the centre of the case and lift out.



## COMPONENT MAINTENANCE MANUAL BA27

### CLEANING

#### 1. General

- A. The following item is required to perform the cleaning procedure.

Soft clean dry cloth

#### 2. Disassembled Battery

- A. Ensure that no particles from the drilled rivets remain in the case.
- B. Wipe the inside of the case and underside of lid with soft clean dry cloth to remove dust or dirt particles.





COMPONENT MAINTENANCE MANUAL  
BA27

CHECK

1. General

A. Battery case and lid. Examine for:

- 1) Cleanliness
- (2) Cracking
- (3) Corrosion

B. Rubber components: Examine for the following defects:

- (1) Signs of perishing
- (2) Deterioration

C. All other components.

- (1) Renew if damaged or showing signs of deterioration.





## COMPONENT MAINTENANCE MANUAL BA27

### REPAIR

#### 1. Unserviceable Monoblocs

**NOTE:** Monoblocs are serial numbered in pairs, the two units carry the same serial number as is shown on the label on the battery container. When re-blocking, the existing label should be removed from the battery container and replaced by a new label carrying the appropriate new serial number.

Re-blocking kits can be purchased from EnerSys Ltd and can be installed by the purchaser. Alternatively, the expired battery can be returned to the manufacturer for re-blocking.

**EnerSys Ltd**  
Stephenson Street  
NEWPORT  
South Wales  
NP19 4XJ  
U. K.

#### 2. Zero Battery Voltage

If the open circuit voltage is recorded as zero, either,

i) Repair unit per A, B, C below.

or

ii) Return battery to address shown in paragraph 1.

If repaired unit in i) still records open circuit voltage as zero, return battery to address in paragraph 1 for an inspection by the manufacturer to determine the cause of failure.

To replace a pair of cell blocks, proceed as follows :-  
Figure references are to IPL.

A. Replace label ( 170 ) on front of outer case assembly ( 30 ) with new label carrying the appropriate new serial number.

B. Remove unserviceable monoblocs (see Disassembly).

C. Renew unserviceable monoblocs (see Assembly)





## COMPONENT MAINTENANCE MANUAL BA27

### ASSEMBLY

#### 1. General

This section describes and provides information for an experienced shop mechanic to assemble batteries with no specialised training.

#### 2. Safety

Same as disassembly.

WARNING: Caution shall be exercised when testing, building and handling batteries, as monoblocs are fully charged and any short circuit condition may result in injury.

WARNING: To avoid risk of injury, care shall be taken when wearing jewellery such as rings, bracelets, metal watchstraps necklaces and belt buckles.

CAUTION: Any such items shall if possible, be removed prior to working on monoblocs or batteries to avoid risk of injury.

CAUTION: All tools coming into contact with the monobloc terminals shall be fully insulated to prevent the risk of a short circuit condition.

NOTE: The ( ) part identification numbers herein are IPL, Figure 1 item numbers.



## COMPONENT MAINTENANCE MANUAL BA27

### 3. Detailed Instructions

A. Insert monoblocs (20) into case.

NOTE: Ensure that monobloc polarity is correct (Ref Fig. 9). The monobloc adjacent to the connector block shall have its positive terminal closest to it.

- (1) To insert the first monobloc, gently prise apart the case walls in the centre and place monobloc in.
- (2) Slide the monobloc up to the inside front wall.
- (3) When inserting the second monobloc, slightly angle it towards the connector block to avoid catching the monobloc packing partition.
- (4) Remove paper backing from AV. Block (160) and insert into the outer case assembly (30) adjacent to the end of the monobloc, when in position it should be level with the top of the monobloc.
- (5) Connect the positive wire to the positive terminal of the rear monobloc using binx nut (140) and plain washer (130), tighten the nut to a torque of 1.0Nm and then place nut cover (1 50) over the terminal.



## COMPONENT MAINTENANCE MANUAL BA27

- (6) Connect the negative wire to the negative terminal of the front monobloc using binx nut (140) and plain washer (130), tighten the nut to a torque of 1.0Nm and then place nut cover (150) over the terminal.
- (7) Locate and fix tie wrap block (110) in position as shown in Figure 11.
- (8) Secure black wire to tie wrap blocks using wire ties (100).
- (9) Take the series lamination (120) connect the two monoblocs together using two binx nuts (140) and two plain washers (130), tighten the nuts to a torque of 1.0Nm and then place nut covers (150) over the terminals.

### B. Fit Lid

- (1) Locate outer case cover assembly (180) to battery, ensuring cut out in cover fits over the handle.
- (2) Ensure holes in case cover (180) aligns with holes in battery case through which pop rivets enter.
- (3) Using 10 rivet fastenings (210), secure case cover to battery case using a pop-rivet gun. Ensure each rivet is located flush to the case cover. On the monobloc vent lid side, ensure the rivet is firmly home prior to completing operation.



COMPONENT MAINTENANCE MANUAL  
BA27

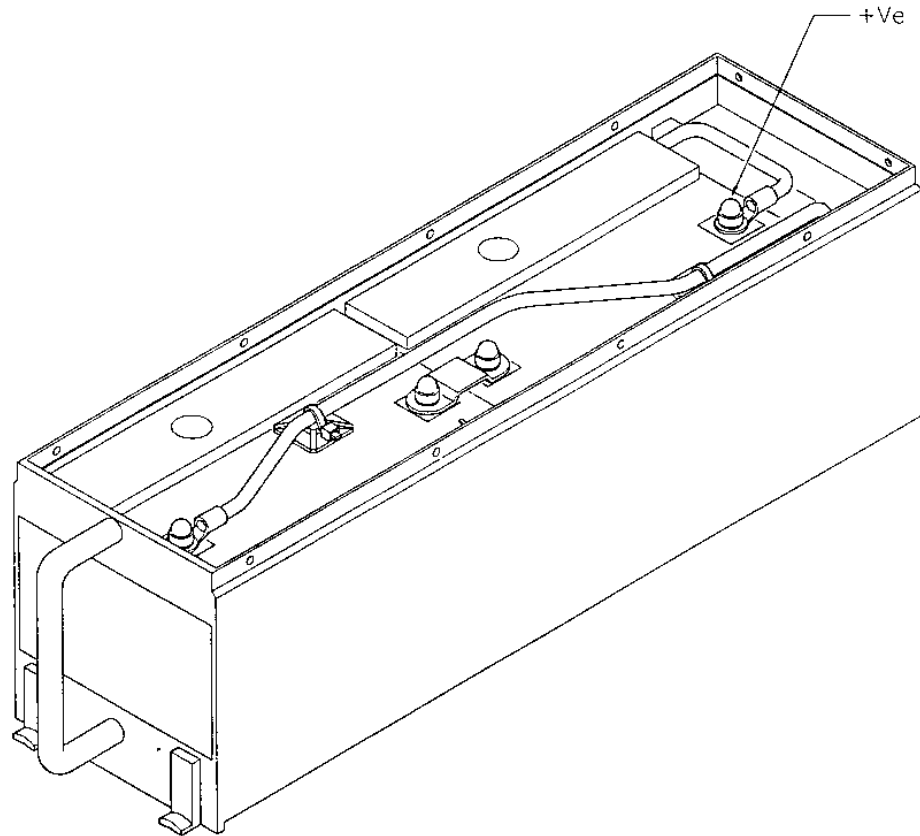

Figure 9



COMPONENT MAINTENANCE MANUAL  
BA27

SPECIAL TOOLS, FIXTURES AND EQUIPEMENT

1. Special Tools

NOTE: Equivalent substitutes may be used for listed items.

A. The equipment detailed in Figure 10 is required to disassemble, test and reassemble batteries.

ITEM NUMBER	ITEM	PART NUMBER
10	Drill	
20	3.2mm (.125") Drill Bit	
30	Torque Spanner & 7mm (.276") Socket	
40	Pop Rivet Gun EFF A, B, C	
50	Battery Disconnect ITT Cannon Ref: DPXBMA-10-33P-0015	2212-9801
60	Pop Rivet Gun, Textron G2 with 1/8" Al MBC Nose Assembly or Handtool 7166 with 1/8" Nose Assembly	

Special Tools, Fixtures and Equipment

Figure 10





## COMPONENT MAINTENANCE MANUAL BA27

### ILLUSTRATED PARTS LIST

#### 1. Introduction

##### A. Purpose

- (1) This section provides illustrations and parts breakdown of the BA27 battery, which can be disassembled, repaired or replaced and reassembled.

##### B. Explanation and Usage of Section

- (1) Assembly Order Indenture Section

The Indenture System used in the parts list shows the relationship of one part to another. For a given item, the number of indentures depicts the relationship of the item to the associated next higher assembly.

- (2) Effectivity Code

Reference letters (A, B, C etc) are assigned in the EFF code column to each top assembly. The reference letter of the applicable top assembly is also shown in the EFF CODE column for each detail part and subassembly except that no reference letter is shown for detail parts and subassemblies used on all top assemblies.

- (3) Quantity Per Assembly

The UNITS PER ASSY column shows the total number of units required per assembly, per subassembly, and per sub subassembly as applicable. The letters REF indicate the item is listed for reference purposes.

- (4) Parts Replacement Data

Interchangeability information will be provided in a future manual revision if it becomes applicable.



## COMPONENT MAINTENANCE MANUAL BA27

(5) Service Bulletin Incorporation

Service Bulletin incorporation information applicable to the parts list will be provided in a future manual revision if it becomes applicable.

(6) Items Not Illustrated

(a) Items not illustrated are indicated by a dash (-) ahead of the item numbers in the FIG, and ITEM NO. column.

(7) Alpha Variant Item Numbers

(a) Alpha variants A-Z (except I and O) are assigned to existing item numbers where necessary to show :

1. Added Items
2. Service Bulletin Configurations
3. Configuration differences
4. Optional parts
5. Product improvement parts (non-service bulletin)

(b) Alpha variant item numbers are not shown on the exploded view when the appearance and location of the alpha variant item is the same as the basic item.

(8) Vendors

The vendor of all parts shown in the parts list is as follows:

VENDOR CODE

NAME/ADDRESS

EnerSys Ltd  
Stephenson Street  
NEWPORT  
South Wales  
NP19 4XJ  
U.K.



COMPONENT MAINTENANCE MANUAL  
BA27

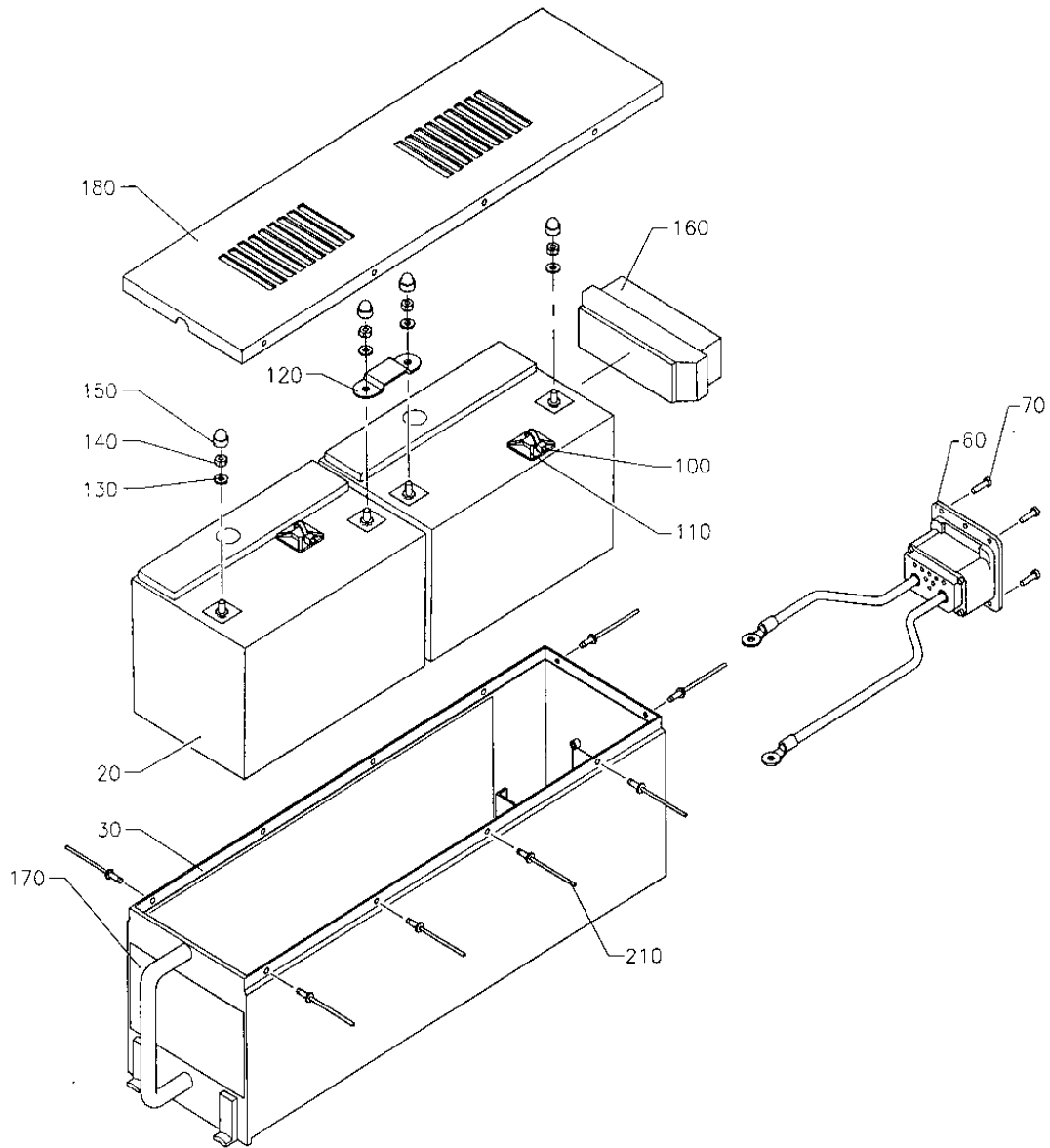

Battery, Exploded View

Figure 1



COMPONENT MAINTENANCE MANUAL  
BA27

ILLUSTRATED PARTS LIST

FIG	ITEM	PART NUMBER	NOMENCLATURE 1234567	EFF CODE	UNITS PER ASSY
1	-10	BA27-01	SEALED LEAD ACID BATTERY (9750B0818)		RF
	20	1478-5090	.MONOBLOC, 5Ah (P/O KIT ITEM 230) Serial No. B0100 to B0176 Serial No. B0177 to B0234 Serial No. B0235 to B0738 Serial No. B0739 - onwards	A B C D	2
	30	3106-9955	.OUTER CASE ASSEMBLY Serial No. B0100 -B0234 Serial No. B0235 -B0738 Serial No. B0739 - onwards	A, B C D	1
	-40	2210-9897	.MONOBLOC PACKING PARTITION		1
	60	3212-9991	.CONNECTOR ASSEMBLY ATTACHING PARTS		
	70	2207-9633	.SCREW	A	4
	-70A	2207-8739	.SCREW	B, C, D	4
	80	2207-9649	.WASHERS	A	4
	90	2207-9634	.NUTS	A	4
	100	2107-9761	*** .WIRE TIE (P/O KIT ITEM 230)		2
	110	2107-9658	.TIE WRAP BLOCK (P/O KIT ITEM 230)		2
	120	2207-9677	.LAMINATION, SERIES (P/O KIT ITEM 230) ATTACHING PARTS		1
	130	2207-9902	.WASHER, PLAIN(P/O KIT ITEM 230)		4
	140	2207-9560	.NUT, BINX (P/O KIT ITEM 230)		4
	150	2201-9930	.NUT, COVER (P/O KIT ITEM 230)	A, C	4
	-150A	2107-9580	.NUT, COVER (P/O KIT ITEM 230)	B	4
	160	2210-9883	.A.V. BLOCK		1
	170	2201-9929	.LABEL, NAMEPLATE (P/O KIT ITEM 230)		1
	180	3106-9952	.OUTER CASE COVER ASSY		1
	-190	2210-9954	.MONOBLOC, HOLD DOWN	A, B	2
	-190A	2210-9845	.MONOBLOC, HOLD DOWN	C, D	2
	-200	2210-9889	.MONOBLOC, HOLD DOWN	A, B	1
	-200A	2210-9844	.MONOBLOC, HOLD DOWN	C, D	1
	210	2207-9630	.RIVET FASTENINGS	A	10
	210A	2207-8738	.RIVET FASTENINGS	B, C	10
	210B	2207-8667	.RIVET FASTENINGS		10
	-220	2201-9556	.POLARITY LABEL (POS)		1
	-230	9250-0142	.REBLOCKING KIT		1

- DENOTES NOT ILLUSTRATED